



紅星篩網

RED STAR  
WIRE SCREENS

— SINCE 1989 —

**SELF-CLEANING SCREENS**

## ▪ **SELF-CLEANING SCREENS**

- Due to the moisture content, plasticity, or shape of the feed material, adhesion to the screen surface or blockage and jamming of screen openings may occur during screening. This significantly reduces the production capacity of the screen and increases machine downtime.
- To address this issue, we offer a series of anti-clogging screens. These screens feature wires arranged in either wavy or straight patterns, with each wire operating independently. Under the influence of machine vibration and the impact and weight of the screened material, the wires generate high-frequency, asynchronous vibrations, thereby accelerating the separation of particles. This allows particles to pass through the screen openings more quickly, significantly increasing output while reducing contact with the metal wires, thereby extending the screen's service life.
- Due to the geometric shape of their openings, these screens offer an extremely high open area ratio. If you aim to enhance the performance of your screening surface, we strongly recommend using them.



## ▪ **Features of the anti-clogging self-cleaning screen mesh**

### Ultra-high screening efficiency

- The anti-clogging self-cleaning screen mesh offers higher screening efficiency than other screen mesh types, increasing output by 30% while eliminating clogged, blocked, or jammed holes, thereby reducing the frequency of downtime for cleaning.
- The self-cleaning screen's frequency-adjustable vibration accelerates material layering, maximizing throughput.
- Longer wear life than woven screens: smooth surface with increased wear-resistant areas.

▪ **Application of anti-clogging self-cleaning screen mesh**

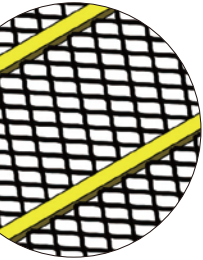

**1 HIGH SCREENING EFFICIENCY**  
Using diamond shaped self-cleaning screens with large mesh sizes to solve the problem of clogging caused by small-sized particles

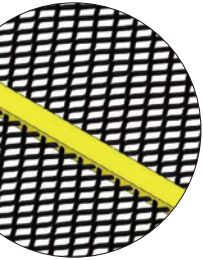

**2 A CLEANER RETAINED PRODUCT**  
The use of diamond shaped self-cleaning screens in the second deck of the screening machine reduces or solves the workload of cleaning clogged holes.



**3 PREVENTS FINE MATERIAL BLINDING**  
The S pattern self-cleaning screens is used in the third deck to prevent the problem of blinding in fine materials.



- Material particles close to the size of the sieve holes cause severe hole jamming.
- It is recommended to use diamond-shaped anti-clogging screens for production comparison



- Coal powder screening in front of the combustion furnace in a thermal power plant
- Traditional woven screens cause serious problems of clogged holes and clogging holes.
- Production resumed after the corrugated anti-clogging screen was replaced.

### 1. Diamond-shaped opening

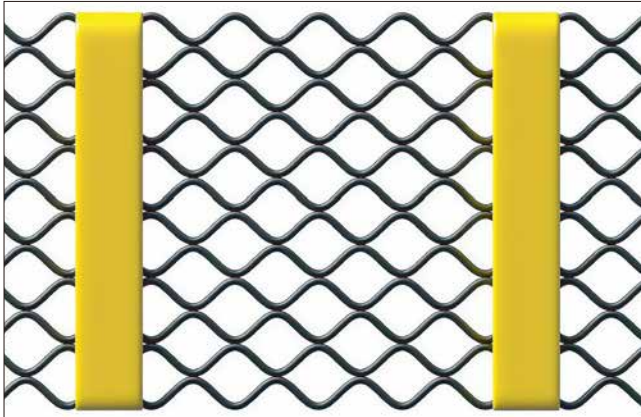

- (1) Standard self-cleaning mesh pattern, most widely used and popular;
- (2) Near-square aperture shape with precise dimensions;
- (3) Independent vibration of mesh wires effectively reduces or prevents clogging, blocking, or jamming of apertures.

### 2. Corrugated Opening (S pattern)

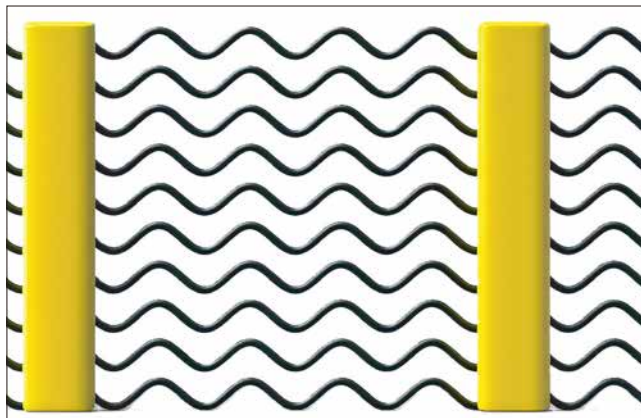

- (1) Suitable for materials with uniform particle shape or when precise screening is not required; prevents screen clogging;
- (2) Reduces the content of fine particles in oversize material; strongly recommended for removing small particles.

### 3. Triangular opening

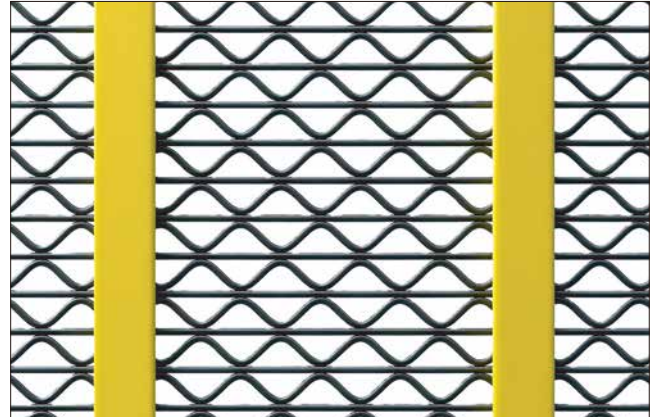

- (1) The style is very similar to the diamond holes, but the accuracy is improved by adding a straight line between the diamond holes, which limits the movement of the screen wire, making the screen hole more precise, but reducing the opening area;
- (2) It can keep the screen hole from deforming under heavy loads and high impact materials;
- (3) It can prevent slender particles from getting stuck in the holes;
- (4) It replaces traditional small-mesh screens to better reduce the blockage phenomenon.

### 4. Piano Screens

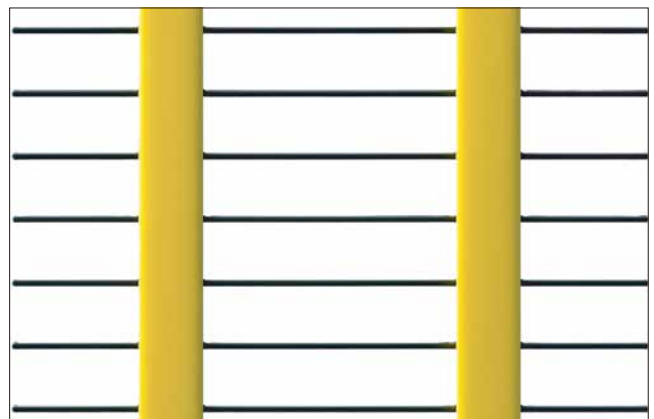

- (1) Has the largest screening area, but lower precision.
- (2) Can screen out fine particles to the greatest extent possible.
- (3) Has a longer lifespan than traditional woven string nets.
- (4) It is mainly used for end-tensioned to sort sand, gravel, and other dry materials.

## Measuring mesh size

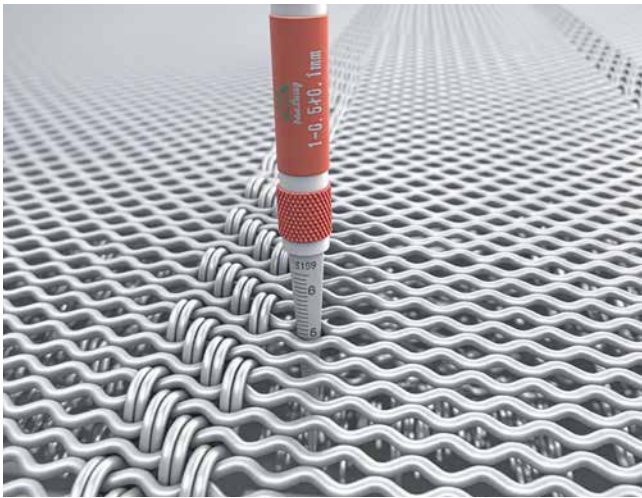

- Mesh aperture refers to the net distance between wire mesh strands;
- Can be measured using a mesh gauge;
- Compared to a tape measure or vernier caliper, mesh size measurement is more accurate.
- It is recommended to measure the mesh size at the first complete mesh hole next to the fixing bar.

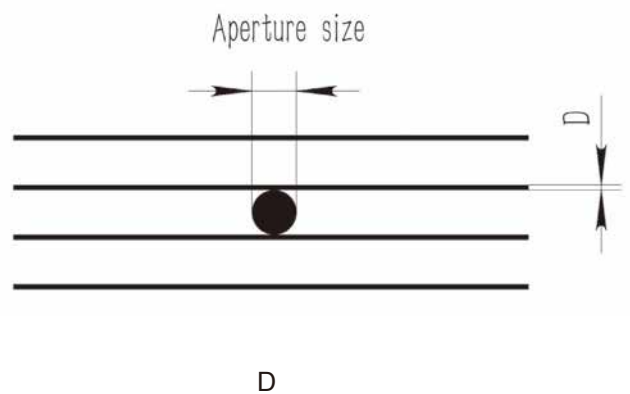
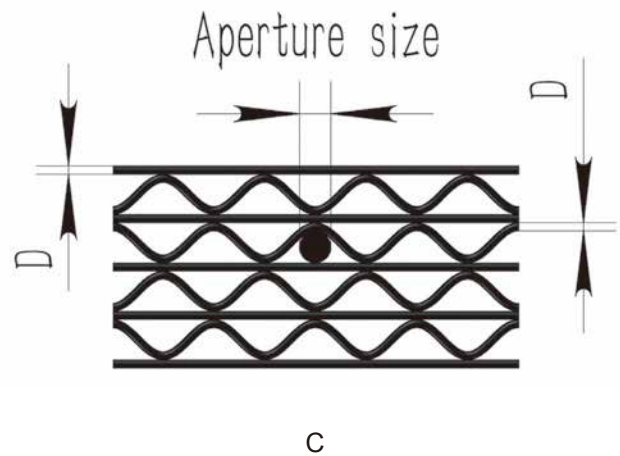
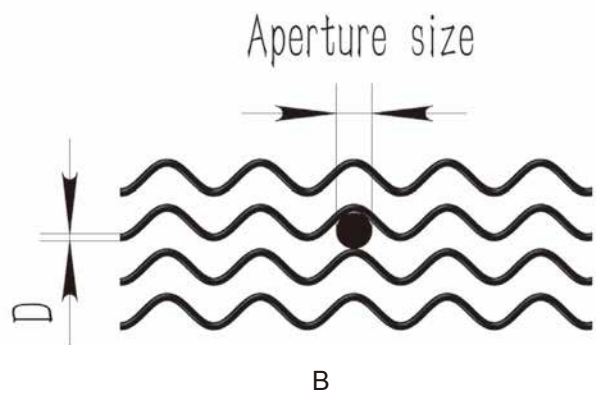
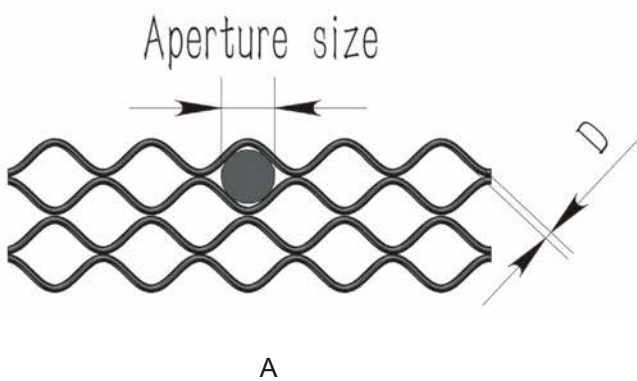

## ▪ *Tensioned Self-cleaning Screen Mesh*

### With Polyurethane Strips



- Polyurethane fixing strips are typically made from Shore A 80° PU, capable of withstanding most aggregate screening applications. They offer excellent wear resistance and extend the service life of screen meshes.
- Heavy-duty thickened strips are suitable for use with high feed rates, highly abrasive materials, soil removal processes, large particles, and large screen openings;
- Thickened strips can serve as guide strips, directing materials back to the screen opening area;
- Suitable for all types of self-cleaning screens.

### Standard Weave Pattern

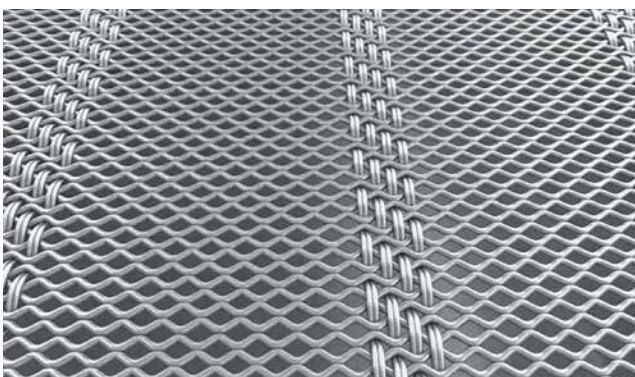

- For applications with temperatures exceeding 70°C.
- Highly recommended for use in asphalt plants.
- Diamond and triangular self-cleaning screens available.

### With Adjustable Fixing Bar



- The movable fixing bar is suitable for any screen machine support beam.
- Primarily used for mobile screening equipment.
- Designed exclusively for piano screens

### With Overlap

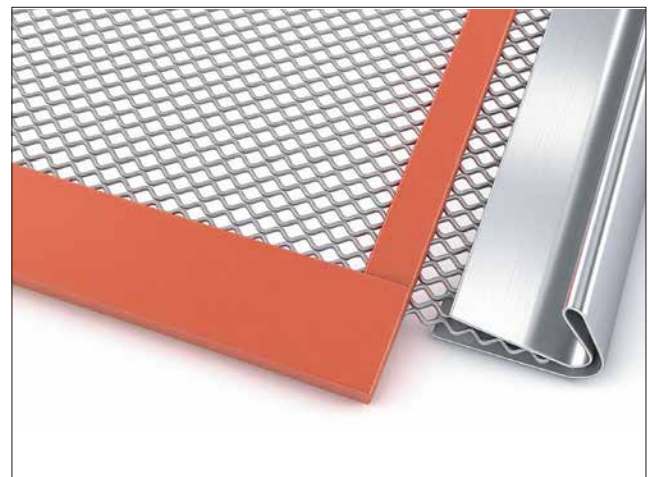

- Suitable for side-tensioned screen meshes;
- Recommended as standard for apertures up to 10mm;
- Compatible with various anti-clogging or woven meshes;
- Maximum aperture of 50mm.

During installation, position the discharge-end screen mesh as the bottom layer, overlapping sequentially toward the feed end.

With Side Sealing

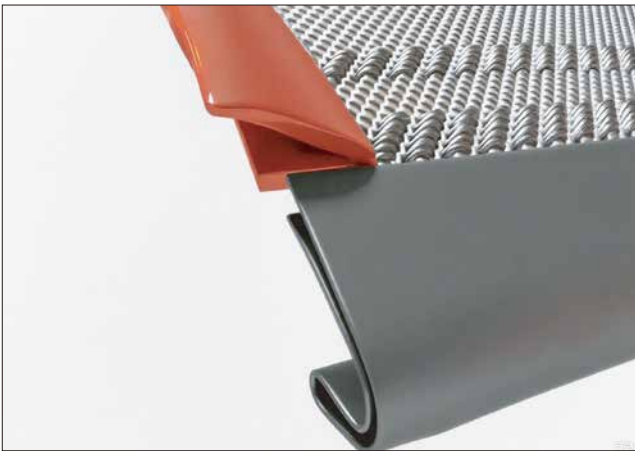

- Optional for all end-tensioned screens.
- Prevents oversized material from passing between the screen edge and the machine side panels.

With Feed End Wear Plate

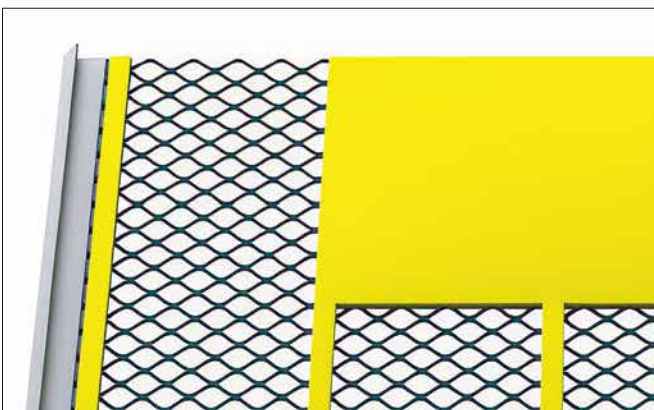

- Used to protect the feed section of the screen plate against wear

All self-cleaning screens utilize polyurethane strips or metal wires arranged at varying intervals to secure the screen wires, thereby maintaining aperture precision. Polyurethane strips should be positioned according to the screen machine's support beam locations.

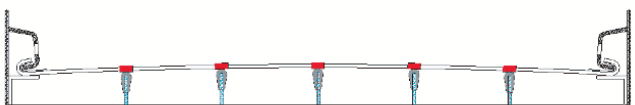

The following issues are likely to cause breakage:

- The curved surface of the screen support is too flat;
- Material is present in the bracket below the hook;
- The screen is not tightly attached to the support beam;
- The screen is stretched unevenly, causing the mesh to sag;
- The fixing bar is not aligned with the support beam;
- J-bolts are used to secure the screen surface.

•Note: The anti-blocking screen must be kept tight; hitting it with a rubber hammer will cause the screen to bounce.



## ■ Installation Instructions

### I. Preparatory Work

Inspect the self-cleaning screen:

- Since the screen wires are individually loose, some wires may appear deformed or loose upon receipt. Please correct this after tensioning.

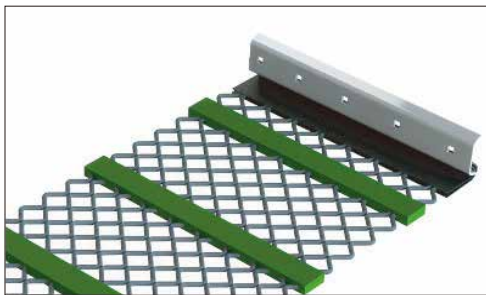

- Ensure the length of the self-cleaning screen matches the tensioning plate. If they do not align, do not proceed with installation, as this may cause damage to the mesh surface during production!

- The width of the mesh surface installed with tension on both sides (measured from the outer edge of one hook to the outer edge of the opposite hook) should be 25-45mm smaller than the inner dimensions of the screening machine.

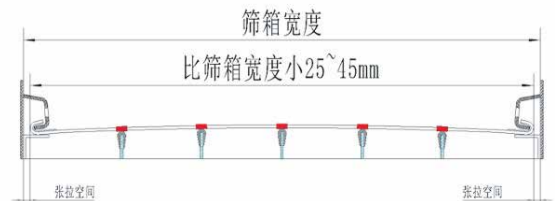

Inspect the screen

- The support beams are not worn, deformed, or asymmetrical;
- The tensioning plates are not worn or deformed;
- The shock-absorbing rubber support strips are not worn, are uniform in size, and are properly installed;
- The incoming material does not directly impact the screen surface;



Note:

- Do not stack any items on the self-cleaning screens;
- Do not store the self-cleaning screens in an upright position to prevent deformation and damage;
- Do not step on the self-cleaning screens;
- Do not bend the self-cleaning screens;
- Do not over-tension the self-cleaning screens;
- Screens with polyurethane strips are for use at temperatures below 80°C.

## ***II. Installation***

- Ensure the support beam forms a complete arc. If incomplete, the mesh will not fit snugly against the beam, leading to premature damage.
- Remove all accumulated fine powder and particles from the screen frame beams.
- The polyurethane strips of the self-cleaning mesh must align with the screen support beams. Misalignment will reduce the effective open area of the screen mesh and shorten its service life.
- Tighten both sides of the fixing bolts simultaneously. If a center clamping plate is present, secure it first after properly positioning the screen mesh (applicable to screens with a single center clamping plate).
- Begin tightening the tensioning bolts from the center and proceed alternately to secure all bolts.
- The screen should be stretched taut like a drumhead, with minimal displacement when pressing the mesh wires.

## ***III. Routine Maintenance***

- Run the screen machine for several minutes under no-load conditions, then stop to check the screen tension. Repeat this process several times.
- Vibrating the screen mesh allows it to break in with the support beams, distributing tension evenly while helping eliminate variations between screen wires.
- After 4 hours of installation and use, the screen tension must be checked to ensure it is properly set. If the screen is not sufficiently tensioned, it may lead to clogged apertures or damage.

## ▪ **Modular Self-cleaning Screens**



- Self-cleaning screens can also be installed on modular screen decks. No modifications are required.
- Standard sizes and flexible customization are available to accommodate mainstream vibrating screen models.
- The single-piece structure allows for partial replacement, reducing maintenance costs by 50%.

## ▪ **Modular Self-cleaning Screens Installation and Fixing Method**

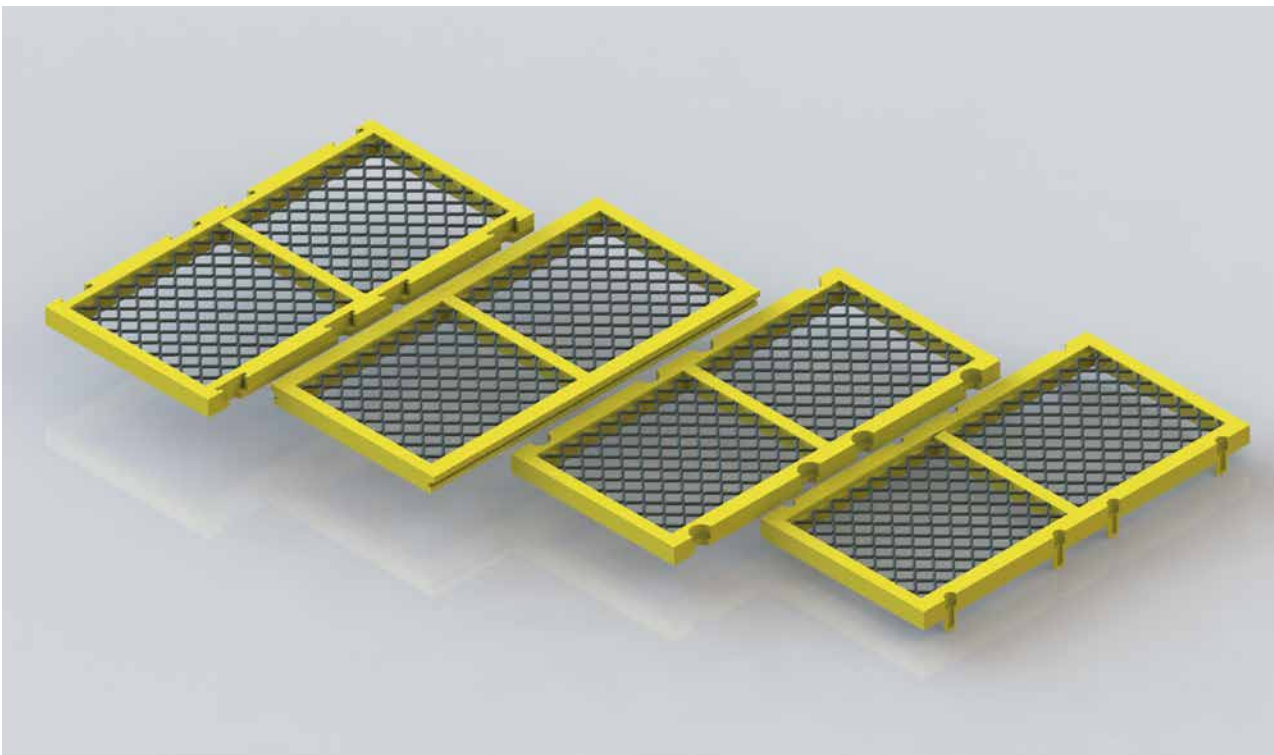

## ▪ *Modular Diamond-Hole Self-Cleaning Screen*

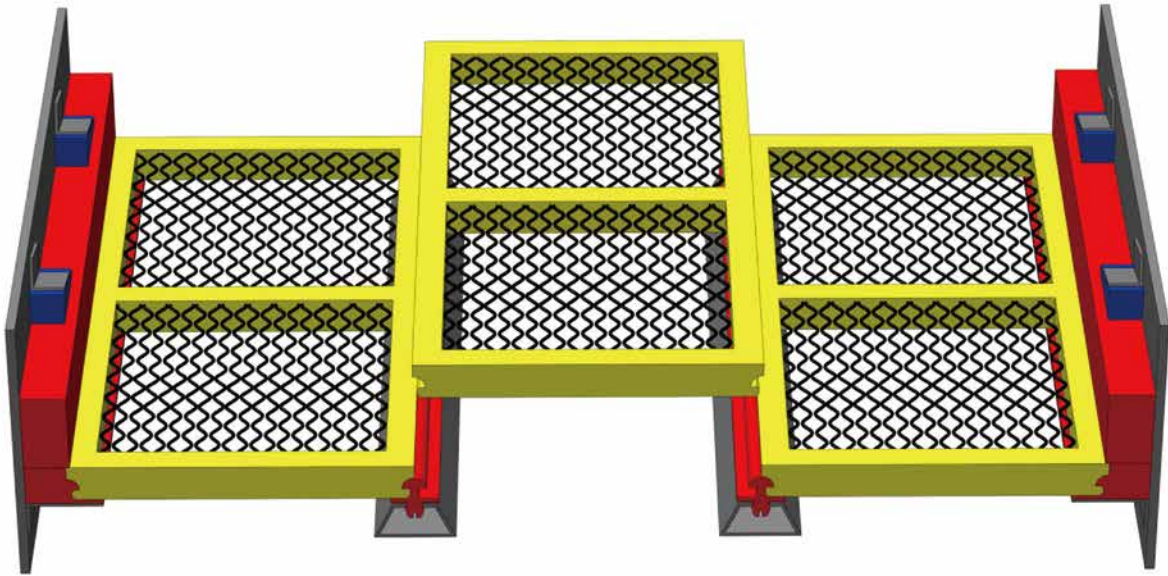

Screen Style

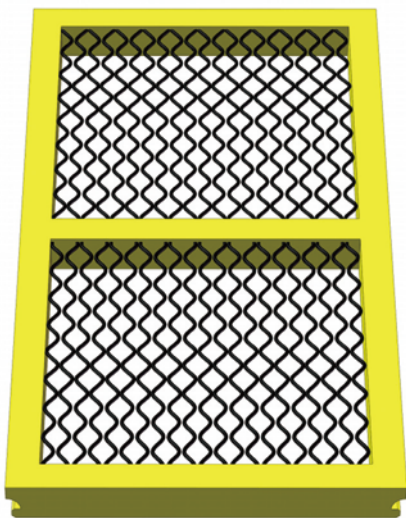

Screen Specification

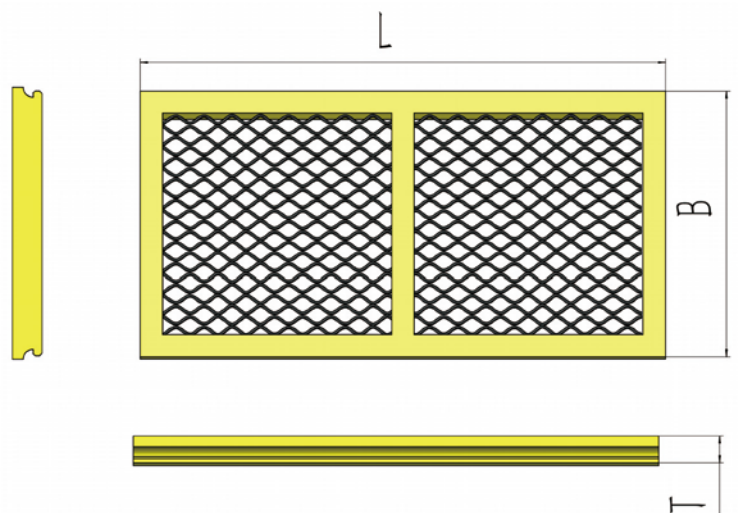

# Accessories

## Adaptive Bar

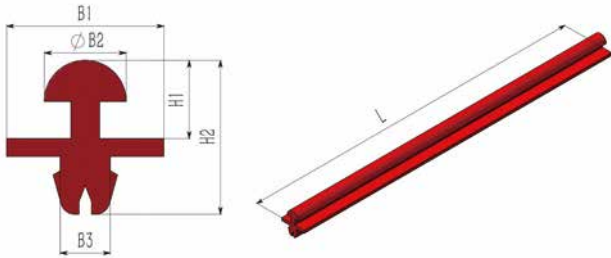

## Side Mounting Bar

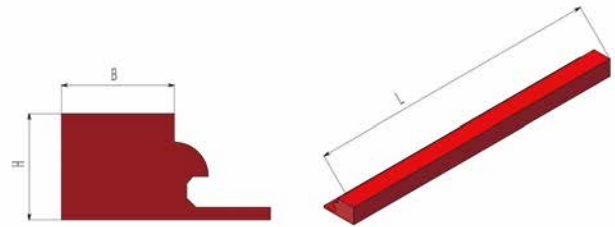

## Side Mounting Bar Standard

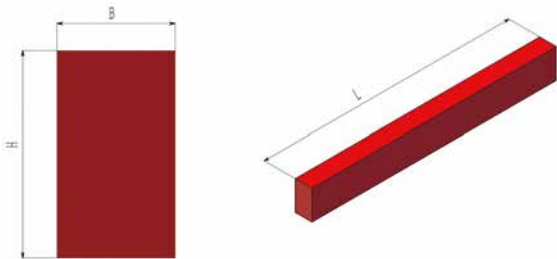

## Wedges

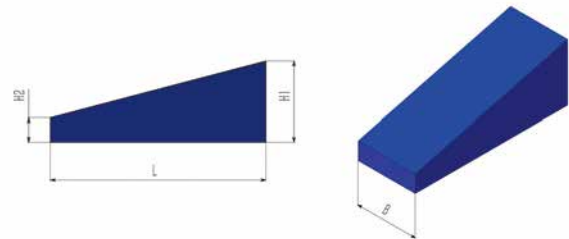

▪ **Modular Corrugated Self-cleaning Screen**

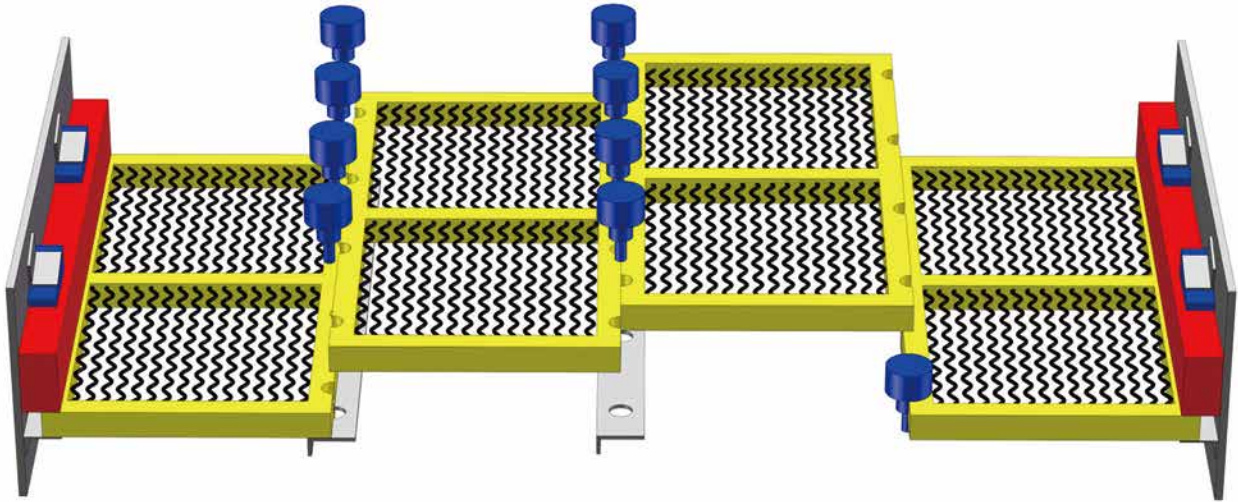

Screen Style

Screen Specification

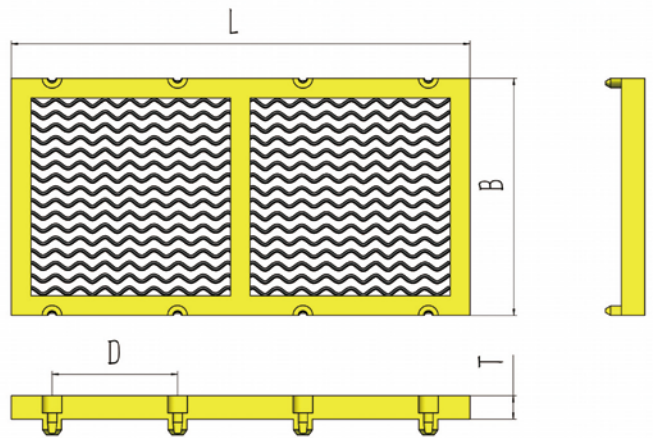
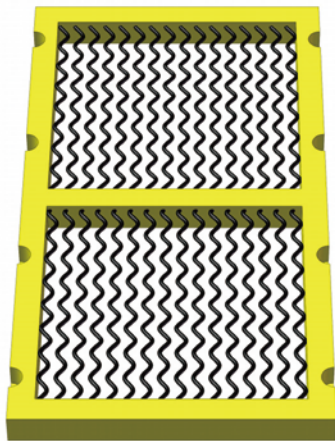

**Accessories**

Side Mounting Bar Standard

Wedges

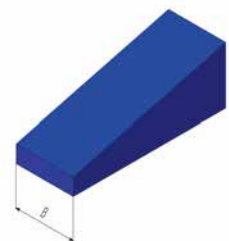
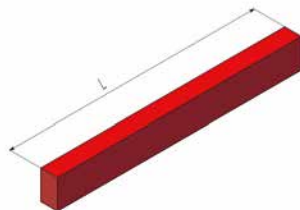
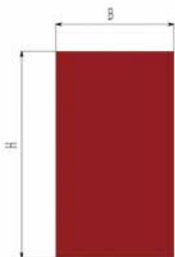

## ▪ *Modular Corrugated Self-cleaning Screen*

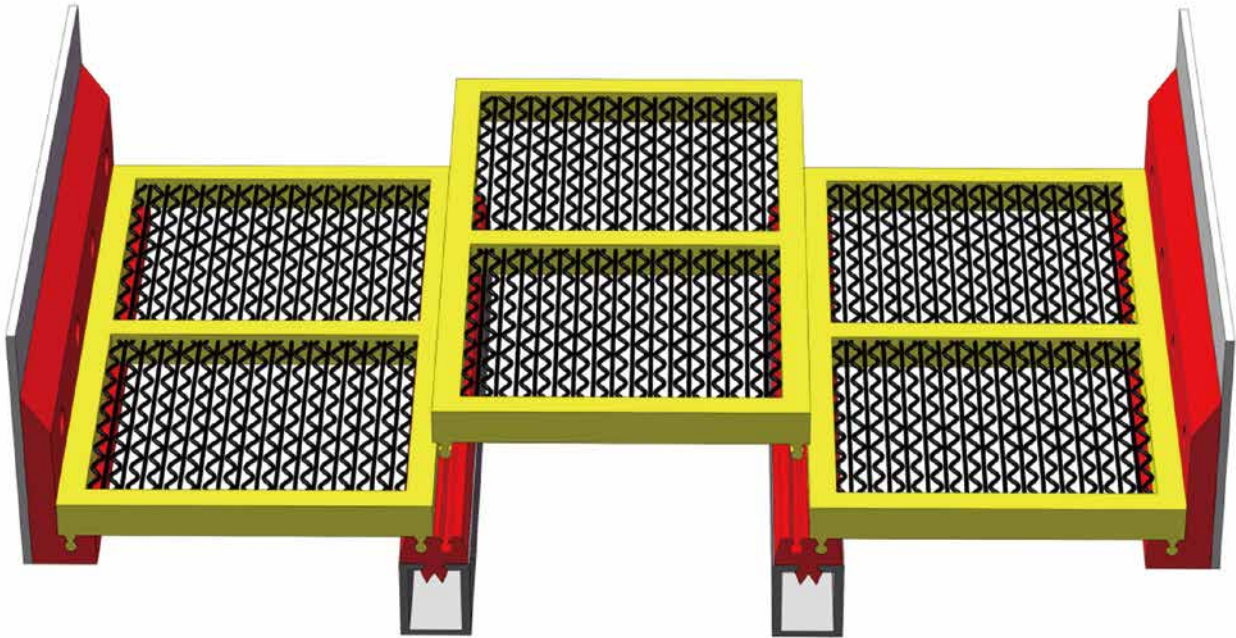

Screen Style

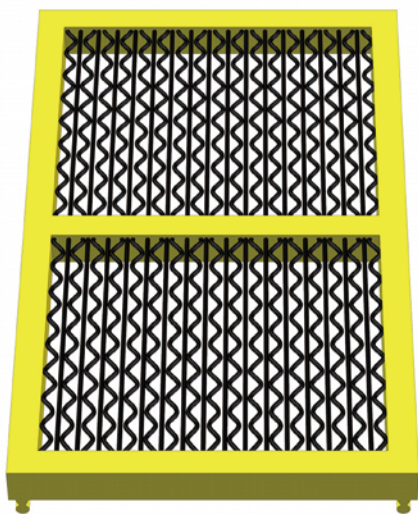

Screen Specification

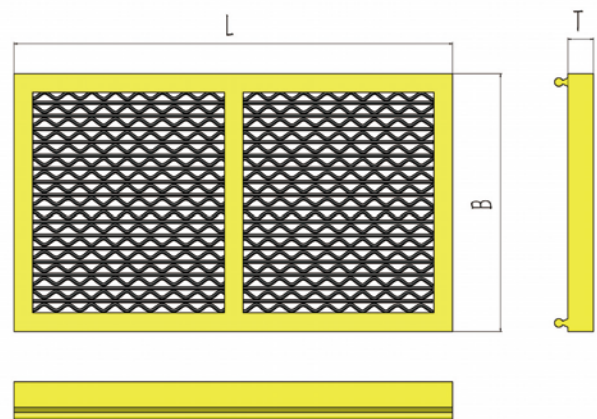

# Accessories

## Side Mounting Bar Standard

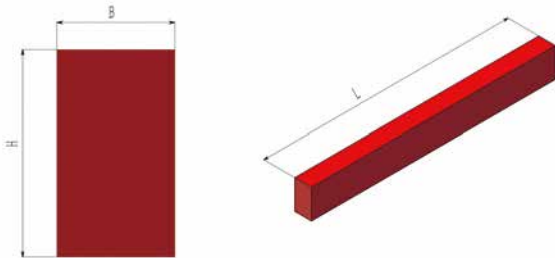

## Wedges

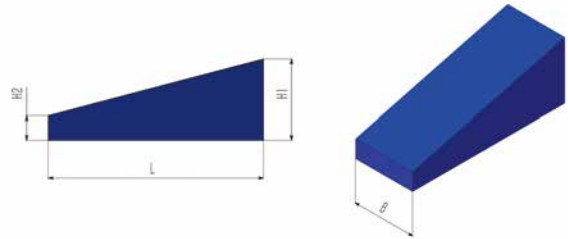

## Side Mounting Bar

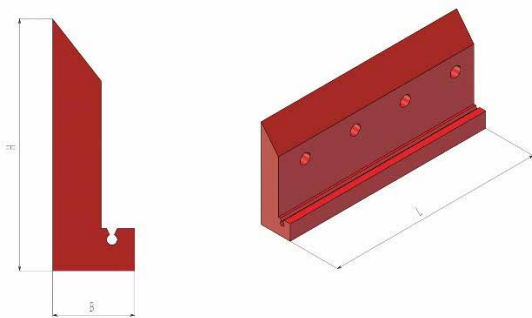

## Adaptive Bar

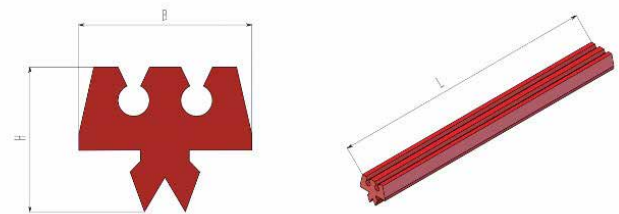

## Pins

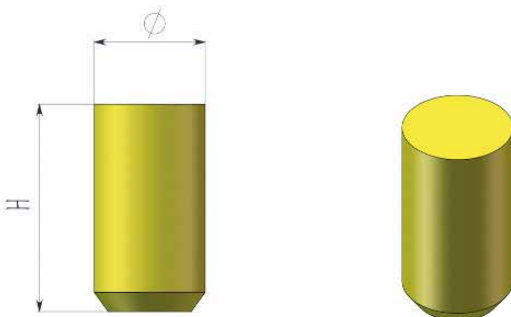



 1 Hongxing Road, Anping County Hebei Province, China

 +86 139 0318 7607/ +86 136 7323 7939 (Whatsapp)

 hanfeng@redstarfactory.com

 [www.redstarscreens.com](http://www.redstarscreens.com)